



2019 STAR CLASS SPRING CHAMPIONSHIP SAILING INSTRUCTIONS

1. Rules

1.1 The regatta will be governed by the rules as defined in *The Racing Rules of Sailing* (RRS) and the rules of the *International Star Class Yacht Racing Association* (ISCYRA), except as changed by the notice of race, the sailing instructions, and any amendments thereto.

1.2 This regatta is a *Red Event* as defined in ISCYRA 34.3.1

1.3 The prescriptions of *US Sailing* will be in effect.

1.4 In the case of a conflict between the notice of race, the sailing instructions, and rules of ISCYRA, the sailing instructions will govern, unless overruled by the jury. (This changes RRS 63.7.)

1.5 ISCYRA rule 31.2.6 is amended to allow VHF radios to be carried on all boats for the purpose of receiving information from the race committee and for use in case of an emergency. The use of cell phones is prohibited except in an emergency.

2. Notices to Competitors

2.1 Notices to competitors will be posted on the official notice board located in the downstairs lobby of the Biscayne Bay Yacht Club.

3. Changes in the Sailing Instructions

3.1 Changes to the *Sailing Instructions* will be posted before 0900 hours on the day it will take effect, except that any change in the schedule of races will be posted by 2000 hours on the day before it will take effect.

4. Bow Numbers

4.1 Each boat will be assigned a bow number by the race committee. Bow numbers will be affixed to the hull in the following manner: The leading edge of the forward number will be 16 inches aft of the stem, and ½ inch below the deck. The leading edge of the aft number shall be 3 inches aft of the aft edge of the forward number, and ½ inch below the deck.

5. Schedule

5.1 Schedule of registration, races, and social events:

Day	Event	Time	Location
April 11 Thursday	Registration Day Registration Desk open	from 0900 to 1200 and from 1600 to 1800	BBYC Foyer
April 12 Friday	Skippers Meeting First Warning Signal A 2 nd race is scheduled to follow After Race Gathering, beer keg and food bar	0900 1100 1700	BBYC Patio Biscayne Bay Southeast of Dinner Key Channel BBYC Patio
April 13 Saturday	First Warning Signal A 2 nd race is scheduled to follow After Race Gathering, beer keg and food bar	1100 1700	Biscayne Bay Southeast of Dinner Key Channel BBYC Patio
April 14 Sunday	First Warning Signal A 2 nd race is scheduled to follow Awards ceremony	1100 1630	Biscayne Bay Southeast of Dinner Key Channel BBYC Patio

2019 Star Spring Championship Sailing Instructions – Page 2

5.2 The scheduled time of the warning signal for the first race each day is 1100 hours.

5.3 If the race committee intends to start another race on the same day flag R will be displayed on the signal boat at the finish. Subsequent races will be held as soon as possible after the end of the previous race. If no more races are to be started on that day the Race Committee will display flag H.

5.4 No warning signal will be made after 1400 hours on Sunday, April 14th, 2019.

6. Signals Ashore

6.1 Signals made ashore will be displayed on the flagpole of the Biscayne Bay Yacht Club.

6.2 Flag AP when displayed ashore means that the start has been postponed. The warning signal will be made not less than 60 minutes after the lowering of the signal.

7. Class Flag

7.1 The class flag shall be a Red Star on a White Flag.

8. Racing Area

8.1 The racing area will be in an area approximately 2-3 miles South of Dinner Key Channel marker #1.

9. Courses

9.1 See APPENDIX #1 COURSE ILLUSTRATIONS

9.2 The course number, compass bearing, and distance to the first mark will be displayed by the race committee signal boat prior to the warning signal.

10. Marks

10.1 For WINDWARD / LEEWARD courses #3 and #4, mark number (1) will be a large inflatable orange cylinder, mark (2) will be a smaller inflatable orange ball. Mark (3) will be either a gate formed by two yellow cylinders, or a single yellow cylinder. If a gate is present boats will pass through the gate from the direction of the prior mark and may round either mark, or if a single yellow mark round it to port.

10.2 For TRIANGLE courses #1 and #2, mark number (1) will be a large inflatable orange cylinder, mark (2) will be a yellow inflatable cylinder, and mark (3) will be a yellow inflatable cylinder. For the finish of course #2, mark number (3) will be replaced by a finish line as described in sailing instruction 14.1.

11. Mandatory Check In

11.1 Prior to the warning signal of a boats first race each day, boats shall sail past the stern of the race committee signal boat until acknowledged. Boats failing to comply with this instruction will receive a DNS score without a hearing. (This changes RRS 63.1, A1, and A5.)

12. The Start

12.1 The starting line will be between the staff displaying an orange flag on a race committee signal boat at the starboard end, and a staff displaying an orange flag on a race committee boat at the port end.

12.2 A boat not starting within five minutes after the starting signal will be scored DNS without a hearing. (This changes ISCYRA rule 34.7.) The word *four* in RRS 29.1 is replaced by the word *five*.

13. Individual Recall

13.1 For a boat(s) identified according to RRS 29.1 as OCS, the bow number(s) or the sail number(s) may be announced on VHF 72. Failure of a boat to be notified, hear her notification, the timing and order of such hails, or the length of time it takes to make a notification shall not be grounds for redress.

(This changes RRS 62.1(a).)

14. The Finish

14.1 The finish line will be between a staff displaying an orange flag on a race committee boat, and a staff displaying an orange flag on a nearby race committee boat.

14.2 Boats not finishing within 15 minutes after the first boat to finish will be scored DNF without a hearing. (This changes RRS 35, A4 and A5.)

15. Time Limit

15.1 The time limit for the first boat to finish is two hours. Boats finishing more than 15 minutes after the first boat to finish will be scored DNF without a hearing. (This changes RRS 35, A4, and A5.)

16. Protests

16.1 Upon finishing or at the first reasonable opportunity, a boat intending to protest, request redress, report penalty turns or retiring shall inform the race committee signal boat either by VHF or direct communication.

2019 Star Spring Championship Sailing Instructions – Page 3

16.2 Protest forms will be available at the jury desk located in the lobby of the Biscayne Bay Yacht Club.

16.3 The protest time limit is 60 minutes after the last boat has finished the last race of the day or the race committee signals no more racing today, whichever is later.

16.4 The *Race Committee Summary* recording boats not having started, not finished, subject to penalties under flag Z or U, taking penalty turns, protesting a boat, requesting redress or retiring for breaking a rule of PART 2 will be posted on the notice board as soon as possible but no later than 30 minutes before the end of protest time. Preliminary finishes will also be posted as soon as possible.

16.5 Notices will be posted on the official protest notice board within 30 minutes of the end of the protest time limit to inform competitors of hearings in which they are parties or named as witnesses.

16.6 On the last day of racing a request for reopening a hearing shall be delivered: Within the protest time limit if the requesting party was informed of the decision on the previous day; No later than 30 minutes after the requesting party was informed. (This changes RRS 66.)

16.7 On the last day of racing a request for redress based on a jury decision shall be delivered no later than 30 minutes after the decision was posted. (This changes RRS 62.2.)

16.8 No photographic imaging shall be admissible as evidence in protest or redress hearings.

17 Scoring

17.1 The *Low Point System*, RRS Appendix A, will apply, with no race excluded. Six races are scheduled. Three races shall be completed to constitute the championship.

18 Liability and Safety

18.1 The safety of a boat and her entire management including insurance, shall be the sole and inescapable responsibility of the owner and/or entrant.

18.2 Competitors withdrawing and leaving the race course before the end of a race will inform the race committee as soon as possible directly or by VHF 72. Competitors not leaving the dock on a race day shall inform the regatta chairman Bruce Harper, cell phone 305-586-0112.

19 Crew Changes

19.1 Any request for a change of crew shall be submitted to the jury in writing prior to 0900 hours on the day of the race for which the change is to be made. If the jury grants permission, it will do so in writing and post it on the official notice board.

20 Team and Private Support Boats

20.1 Towing of competitors boats before the first warning signal of each day is permitted. Towing is also permitted after the race committee has ended racing for the day. Except for towing no competing boat shall receive outside assistance from support boats or other sources after the first warning signal each day, until after the race committee has ended racing for the day.

20.2 Coach boats and private spectator boats are expected to render assistance to a boat in danger if requested by the boat, the race committee, or the jury. Coach and support boats shall monitor VHF 72 at all times while on the water. Otherwise, coach and support boats will stay 100 meters outside areas where boats are racing.

22 Prizes

22.1 Prizes will be awarded to the skipper and crew finishing first through third place overall.

23 Disclaimer of Liability

23.1 Participants agree that no person or organization involved in the conduct of this Championship will be liable for any accident, injury, fatality, or damage or loss of boat or personal property arising out of a participant's preparation for or participation in any on-the-water or on-shore activities (whether social, recreational, launching, hauling, boat storage or otherwise) associated with the Championship. Nothing in these Sailing Instructions or oral statements by the Organizing Authority, their officers, directors or agents, shall modify or otherwise impair the effect of the Waiver of Liability Form, the execution of which is a condition of entry.

24. ADDITIONAL INFORMATION

Contact Regatta Chairman

Bruce Harper

Cell; 305-586-0112 email; wbruceharpr@hotmail.com

APPENDIX #1
COURSE ILLUSTRATIONS

EXAMPLE: COURSE BOARD DISPLAYED ON R/C SIGNAL BOAT

Sail Course #4 - Windward, Leeward, Windward, Leeward (finish)

With **Offset** at the weather mark, and a **Gate** at leeward mark.
The Weather mark is **1.8 miles** from start at **120°** magnetic.

4
120°
1.8 nm

A1. COURSE DIAGRAMS:

A1.1 Courses 1, 2, 3, and 4 are described below.

Course 1.

An isosceles right angled triangle, followed by finishing on a final windward leg.

Course 1

- Start
- 1
- 2
- 3
- Finish (upwind)

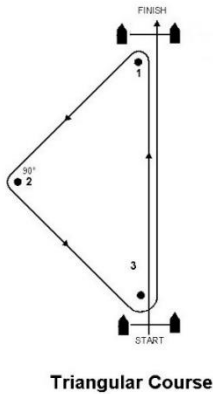

Course 3.

Two complete windward-leeward laps with an offset mark at the windward end and a gate at the leeward end, finishing on a final windward leg.

Course "3"

- Start
- 1
- 2
- 3 (or gate 3A-3B)
- 1
- 2
- 3 (or gate 3A-3B)
- Finish (upwind)

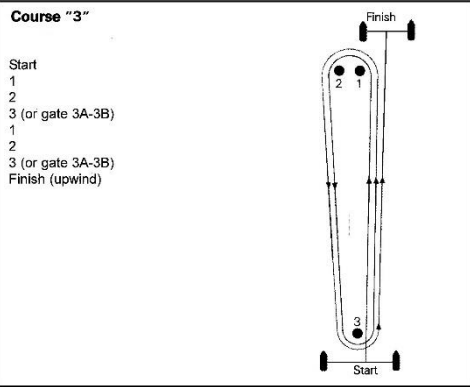

Course 2.

Two isosceles right angled triangles, finishing downwind at the end of the 2nd lap as described in 14.1. (The leeward mark #3 being omitted after the first round.)

Course 2

- Start
- 1
- 2
- 3
- 1
- 2
- Finish (downwind reach)

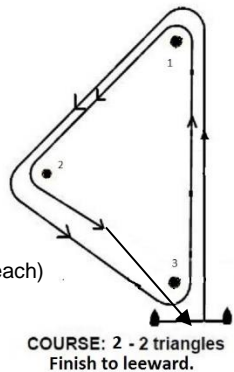

Course 4.

Two complete windward-leeward laps with an offset mark at the windward end and a gate at the leeward end. Finish to leeward at the end of the 2nd lap.

Course "4"

- Start
- 1
- 2
- 3 (or gate 3A - 3B)
- 1
- 2
- Finish (downwind)

